

# COMBATTANTS 140

ENVOYÉ PAR

leyth@virtualize.vip

---

CRÉÉ LE

2022-01-19

<b>Surface totale</b> 121.41 m <sup>2</sup>	<b>Étages</b> 2	<b>Pièces</b> 5	<b>Salle de bain</b> 1
--	--------------------	--------------------	---------------------------

# COMBATTANTS 140

SURFACE TOTALE : 121.41 m<sup>2</sup> • SURFACE HABITABLE : 121.41 m<sup>2</sup> • ÉTAGES : 2 • PIÈCES : 5



## ▼ 1er étage

SURFACE TOTALE : 109.08 m<sup>2</sup> • SURFACE HABITABLE : 109.08 m<sup>2</sup> • PIÈCES : 4

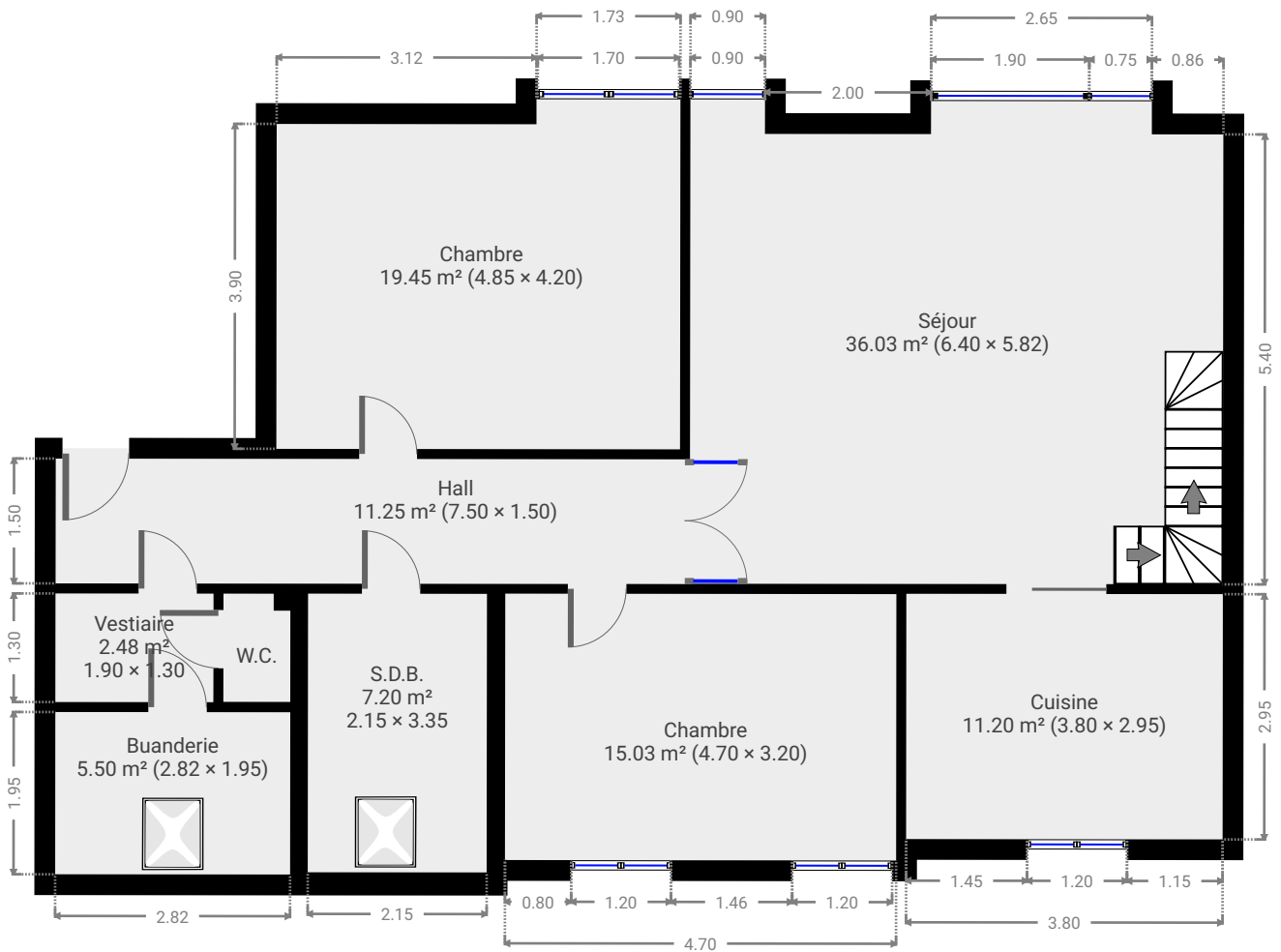
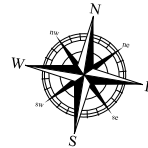

THIS FLOORPLAN IS PROVIDED WITHOUT WARRANTY OF ANY KIND. SENSOPIA DISCLAIMS ANY WARRANTY INCLUDING, WITHOUT LIMITATION, SATISFACTORY QUALITY OR ACCURACY OF DIMENSIONS.

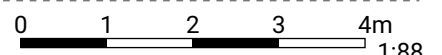

# COMBATTANTS 140

SURFACE TOTALE : 121.41 m<sup>2</sup> • SURFACE HABITABLE : 121.41 m<sup>2</sup> • ÉTAGES : 2 • PIÈCES : 5



## ▼ Hall 1er étage

LARGEUR : 7.50 m • LONGUEUR : 1.50 m  
SURFACE : 11.25 m<sup>2</sup> • PÉRIMÈTRE : 18.00 m

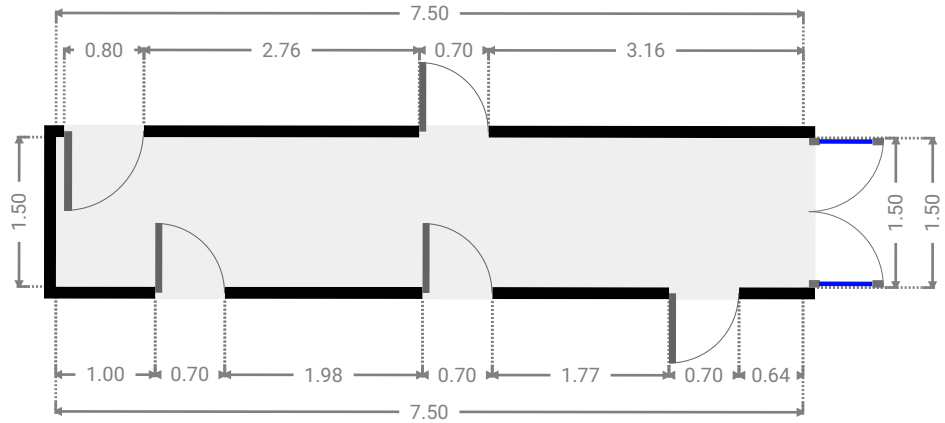
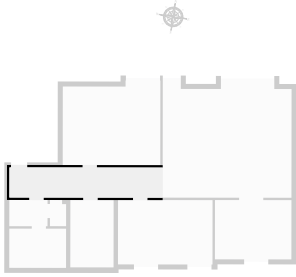

## ▼ Chambre 1er étage

LARGEUR : 4.85 m • LONGUEUR : 4.20 m  
SURFACE : 19.45 m<sup>2</sup> • PÉRIMÈTRE : 18.10 m

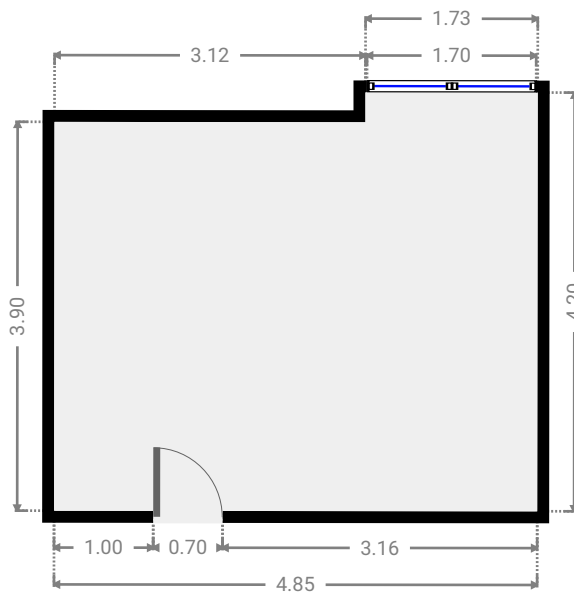
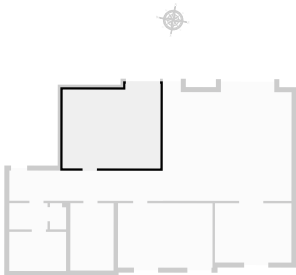

# COMBATTANTS 140

SURFACE TOTALE : 121.41 m<sup>2</sup> • SURFACE HABITABLE : 121.41 m<sup>2</sup> • ÉTAGES : 2 • PIÈCES : 5



## ▼ Vestiaire 1er étage

LARGEUR : 1.90 m • LONGUEUR : 1.30 m  
SURFACE : 2.48 m<sup>2</sup> • PÉRIMÈTRE : 6.40 m

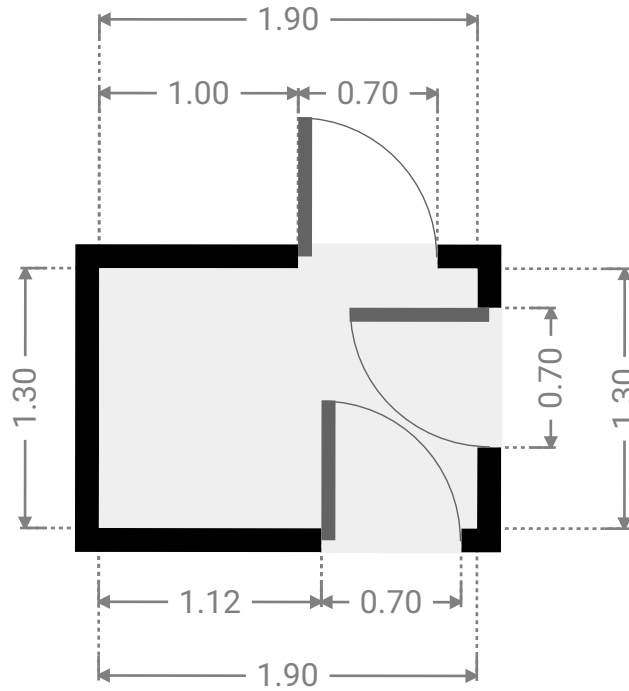
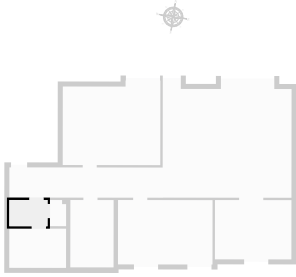

## ▼ W.C. 1er étage

LARGEUR : 0.80 m • LONGUEUR : 1.30 m  
SURFACE : 1.00 m<sup>2</sup> • PÉRIMÈTRE : 4.21 m

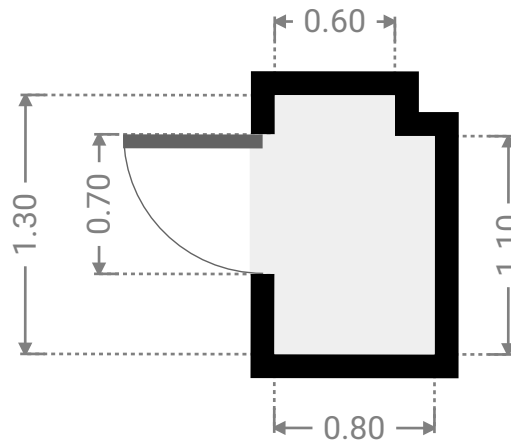
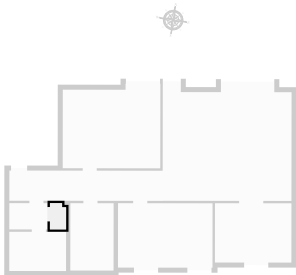

# COMBATTANTS 140

SURFACE TOTALE : 121.41 m<sup>2</sup> • SURFACE HABITABLE : 121.41 m<sup>2</sup> • ÉTAGES : 2 • PIÈCES : 5



## ▼ Buanderie 1er étage

LARGEUR : 2.82 m • LONGUEUR : 1.95 m  
SURFACE : 5.50 m<sup>2</sup> • PÉRIMÈTRE : 9.54 m

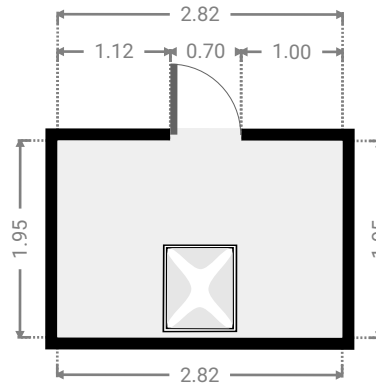
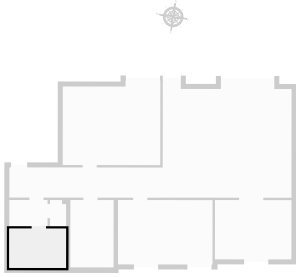

## ▼ Séjour 1er étage

LARGEUR : 6.40 m • LONGUEUR : 5.82 m  
SURFACE : 36.03 m<sup>2</sup> • PÉRIMÈTRE : 25.24 m

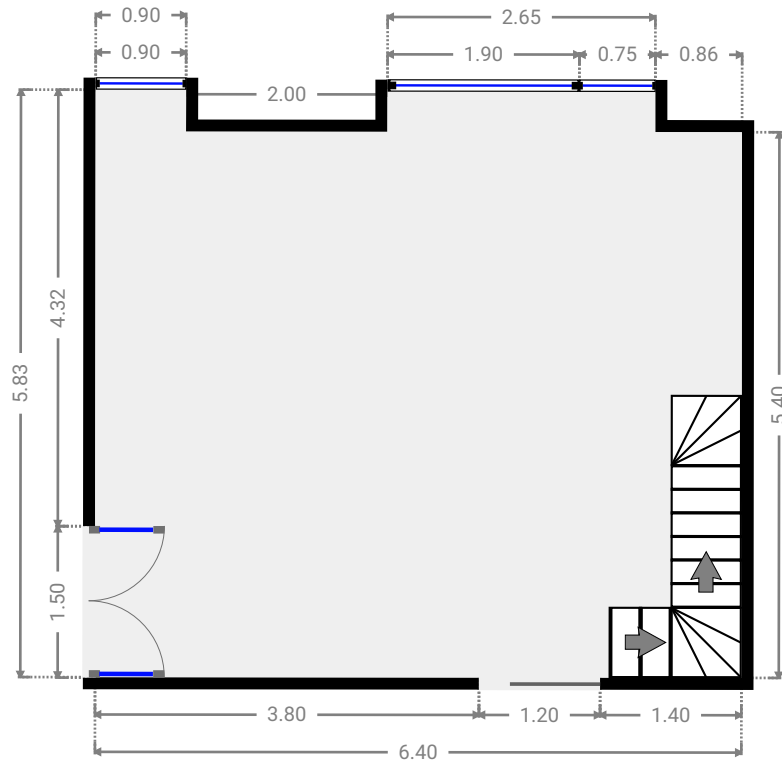
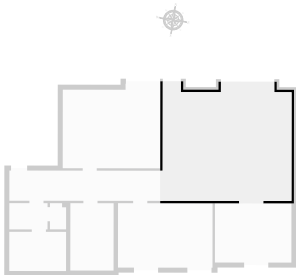

THIS FLOORPLAN IS PROVIDED WITHOUT WARRANTY OF ANY KIND. SENSOPIA DISCLAIMS ANY WARRANTY INCLUDING, WITHOUT LIMITATION, SATISFACTORY QUALITY OR ACCURACY OF DIMENSIONS.

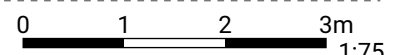

# COMBATTANTS 140

SURFACE TOTALE : 121.41 m<sup>2</sup> • SURFACE HABITABLE : 121.41 m<sup>2</sup> • ÉTAGES : 2 • PIÈCES : 5



## ▼ Cuisine 1er étage

LARGEUR : 3.80 m • LONGUEUR : 2.95 m  
SURFACE : 11.20 m<sup>2</sup> • PÉRIMÈTRE : 13.50 m

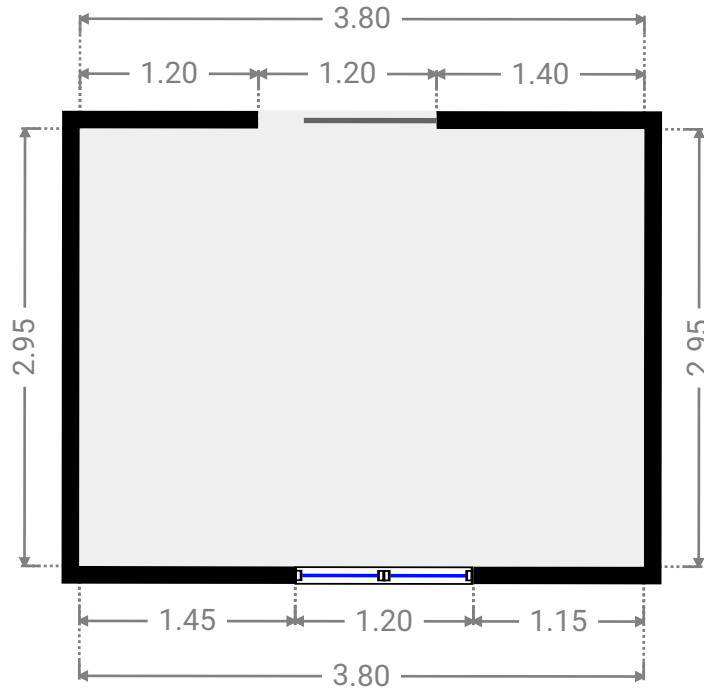
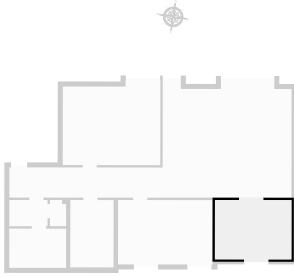

## ▼ Chambre 1er étage

LARGEUR : 4.70 m • LONGUEUR : 3.20 m  
SURFACE : 15.03 m<sup>2</sup> • PÉRIMÈTRE : 15.80 m

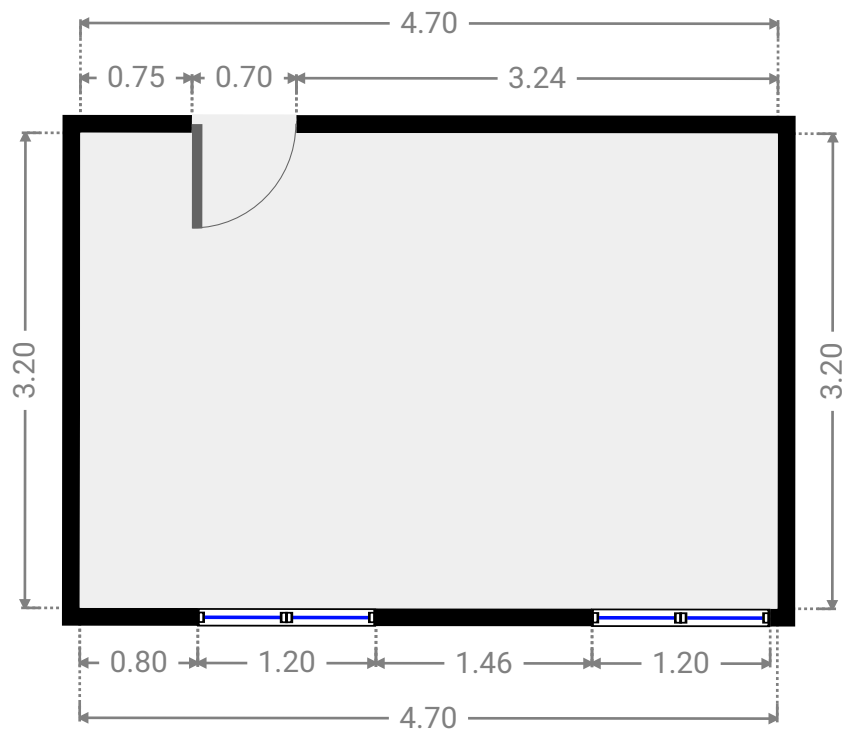
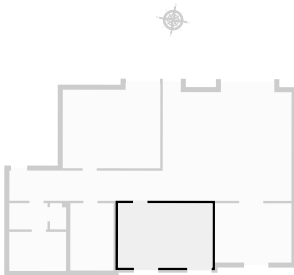

# COMBATTANTS 140

SURFACE TOTALE : 121.41 m<sup>2</sup> • SURFACE HABITABLE : 121.41 m<sup>2</sup> • ÉTAGES : 2 • PIÈCES : 5



## ▼ S.D.B. 1er étage

LARGEUR : 2.15 m • LONGUEUR : 3.35 m  
SURFACE : 7.20 m<sup>2</sup> • PÉRIMÈTRE : 10.99 m

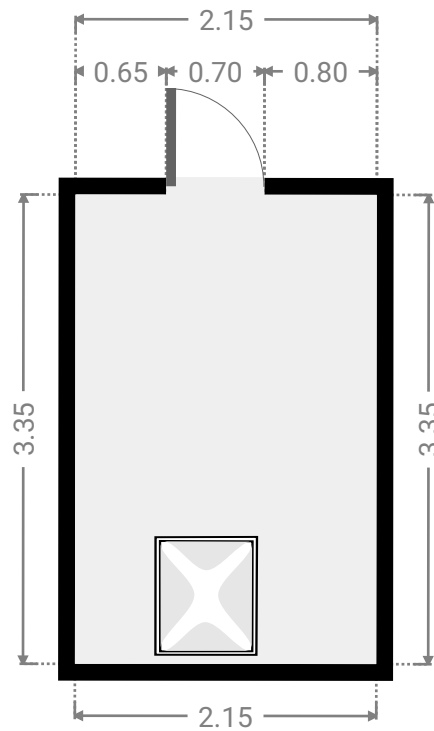
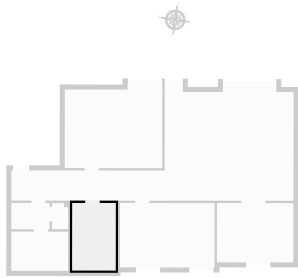

# COMBATTANTS 140

SURFACE TOTALE : 121.41 m<sup>2</sup> • SURFACE HABITABLE : 121.41 m<sup>2</sup> • ÉTAGES : 2 • PIÈCES : 5



## ▼ 2e étage

SURFACE TOTALE : 12.32 m<sup>2</sup> • SURFACE HABITABLE : 12.32 m<sup>2</sup> • PIÈCES : 1

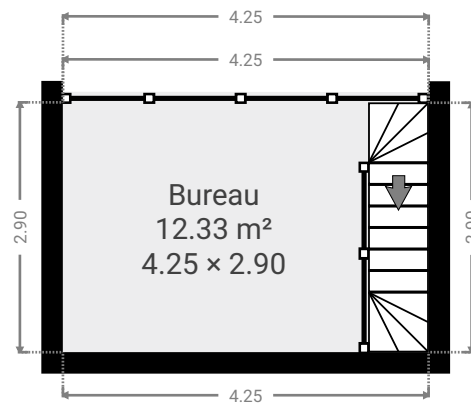



# COMBATTANTS 140

SURFACE TOTALE : 121.41 m<sup>2</sup> • SURFACE HABITABLE : 121.41 m<sup>2</sup> • ÉTAGES : 2 • PIÈCES : 5



## ▼ Bureau 2e étage

LARGEUR : 4.25 m • LONGUEUR : 2.90 m  
SURFACE : 12.33 m<sup>2</sup> • PÉRIMÈTRE : 14.30 m

