

ZILVERBEEKDREEF 19

CRÉÉ LE
2022-04-28

Surface totale 245.88 m ²	Étages 3	Pièces 9	Salles de bain 2
--	--------------------	--------------------	----------------------------

ZILVERBEEKDREEF 19

SURFACE TOTALE : 245.88 m² • SURFACE HABITABLE : 211.09 m² • ÉTAGES : 3 • PIÈCES : 9



▼ Sous-sol

SURFACE TOTALE : 60.23 m² • SURFACE HABITABLE : 25.45 m² • PIÈCES : 2

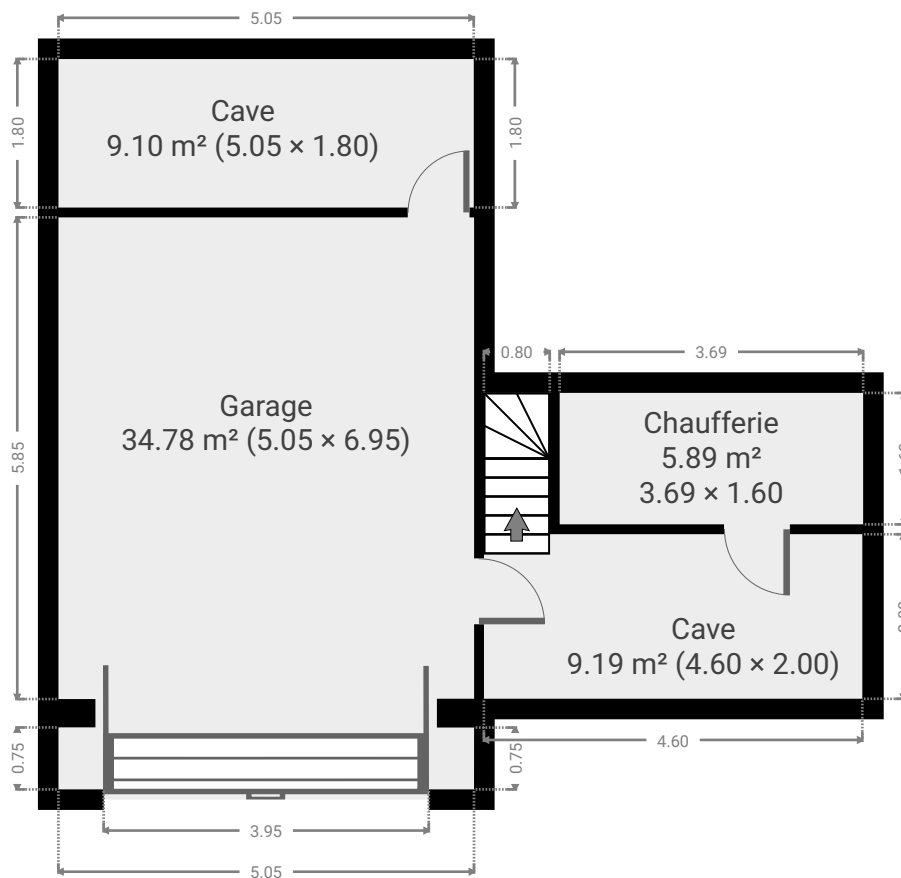

ZILVERBEEKDREEF 19

SURFACE TOTALE : 245.88 m² • SURFACE HABITABLE : 211.09 m² • ÉTAGES : 3 • PIÈCES : 9



▼ Garage Sous-sol

LARGEUR : 5.05 m • LONGUEUR : 6.95 m
SURFACE : 34.78 m² • PÉRIMÈTRE : 25.80 m

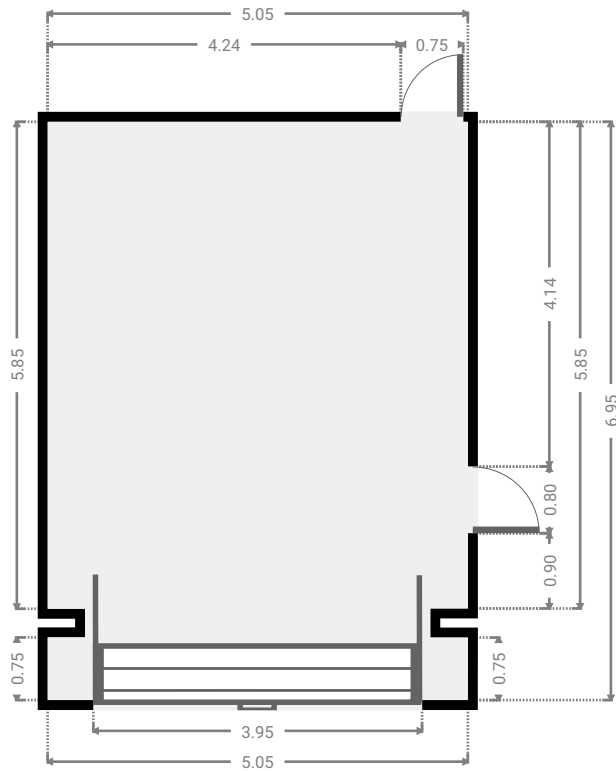
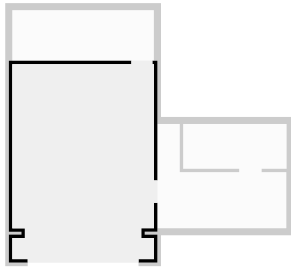

▼ Cave Sous-sol

LARGEUR : 5.05 m • LONGUEUR : 1.80 m
SURFACE : 9.10 m² • PÉRIMÈTRE : 13.70 m

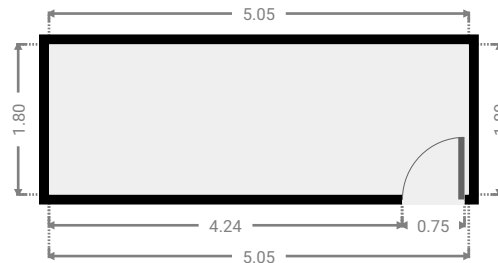
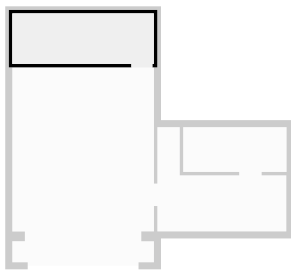

ZILVERBEEKDREEF 19

SURFACE TOTALE : 245.88 m² • SURFACE HABITABLE : 211.09 m² • ÉTAGES : 3 • PIÈCES : 9



▼ Cave Sous-sol

LARGEUR : 4.60 m • LONGUEUR : 2.00 m
SURFACE : 9.19 m² • PÉRIMÈTRE : 13.19 m

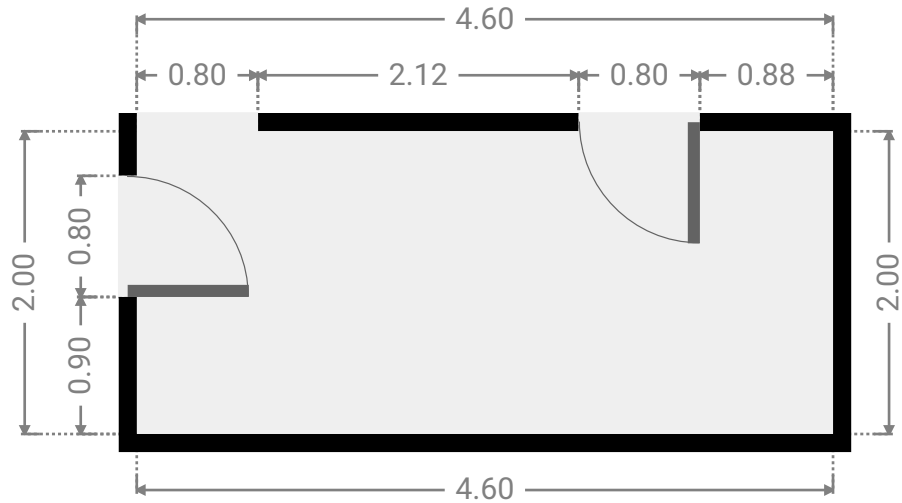
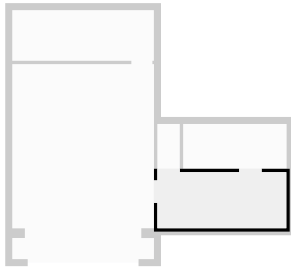

▼ Chaufferie Sous-sol

LARGEUR : 3.69 m • LONGUEUR : 1.60 m
SURFACE : 5.89 m² • PÉRIMÈTRE : 10.57 m

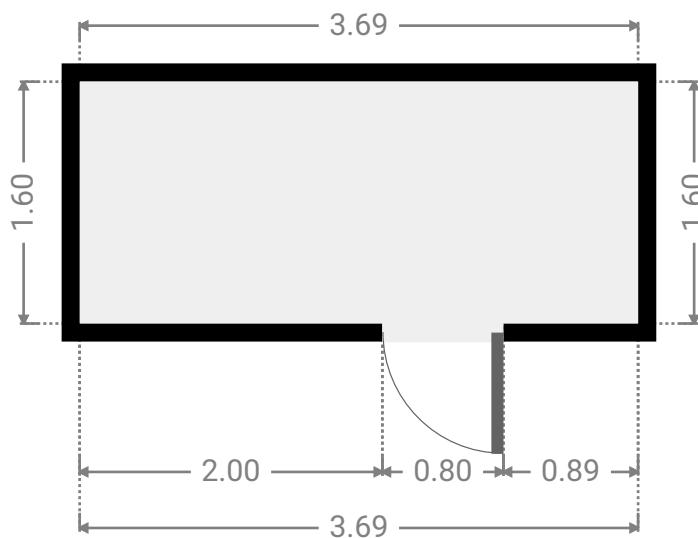
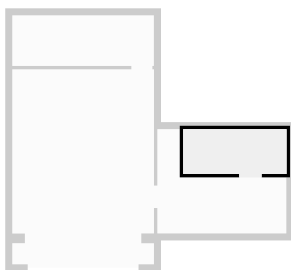

ZILVERBEEKDREEF 19

SURFACE TOTALE : 245.88 m² • SURFACE HABITABLE : 211.09 m² • ÉTAGES : 3 • PIÈCES : 9



▼ Escalier Sous-sol

LARGEUR : 0.80 m • LONGUEUR : 1.60 m
SURFACE : 1.28 m² • PÉRIMÈTRE : 4.80 m

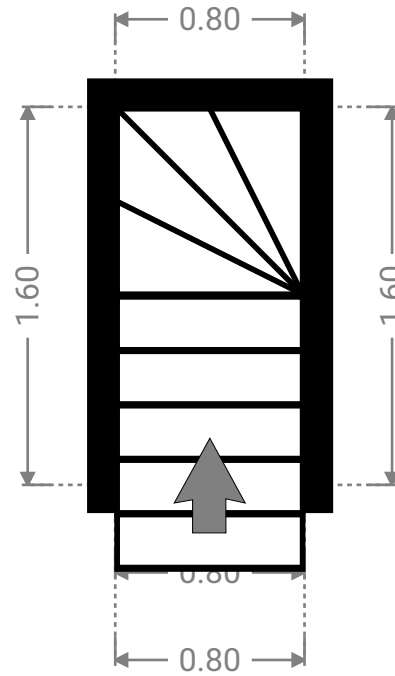
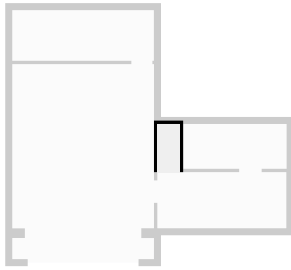

ZILVERBEEKDREEF 19

SURFACE TOTALE : 245.88 m² • SURFACE HABITABLE : 211.09 m² • ÉTAGES : 3 • PIÈCES : 9



▼ Rez-de-chaussée

SURFACE TOTALE : 100.98 m² • SURFACE HABITABLE : 100.98 m² • PIÈCES : 3

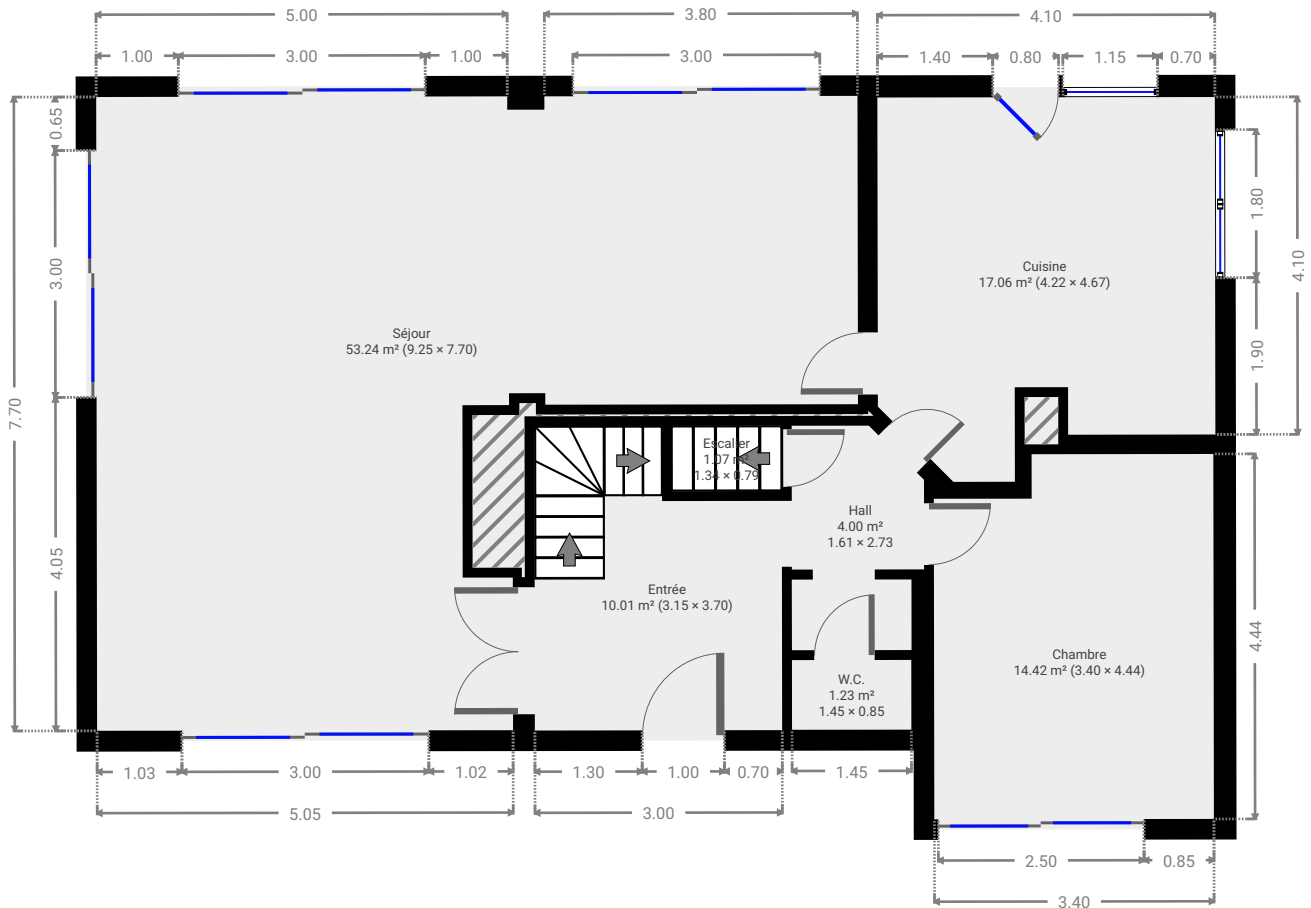

THIS FLOORPLAN IS PROVIDED WITHOUT WARRANTY OF ANY KIND. SENSOPIA DISCLAIMS ANY WARRANTY INCLUDING, WITHOUT LIMITATION, SATISFACTORY QUALITY OR ACCURACY OF DIMENSIONS.

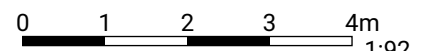

ZILVERBEEKDREEF 19

SURFACE TOTALE : 245.88 m² • SURFACE HABITABLE : 211.09 m² • ÉTAGES : 3 • PIÈCES : 9



▼ Cuisine Rez-de-chaussée

LARGEUR : 4.22 m • LONGUEUR : 4.67 m
SURFACE : 17.06 m² • PÉRIMÈTRE : 18.41 m

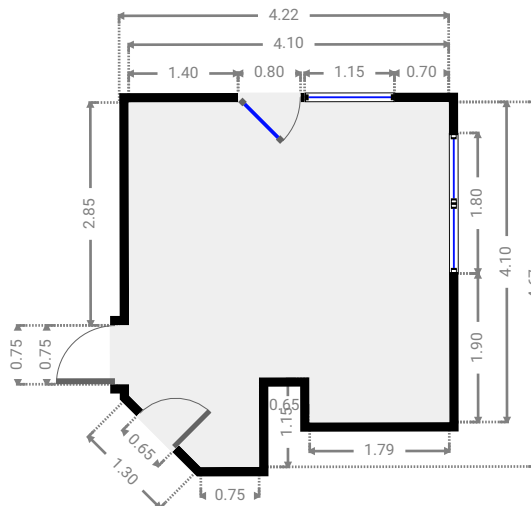
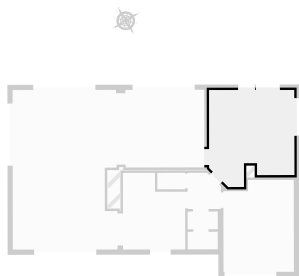

▼ Séjour Rez-de-chaussée

LARGEUR : 9.25 m • LONGUEUR : 7.70 m
SURFACE : 53.24 m² • PÉRIMÈTRE : 35.73 m

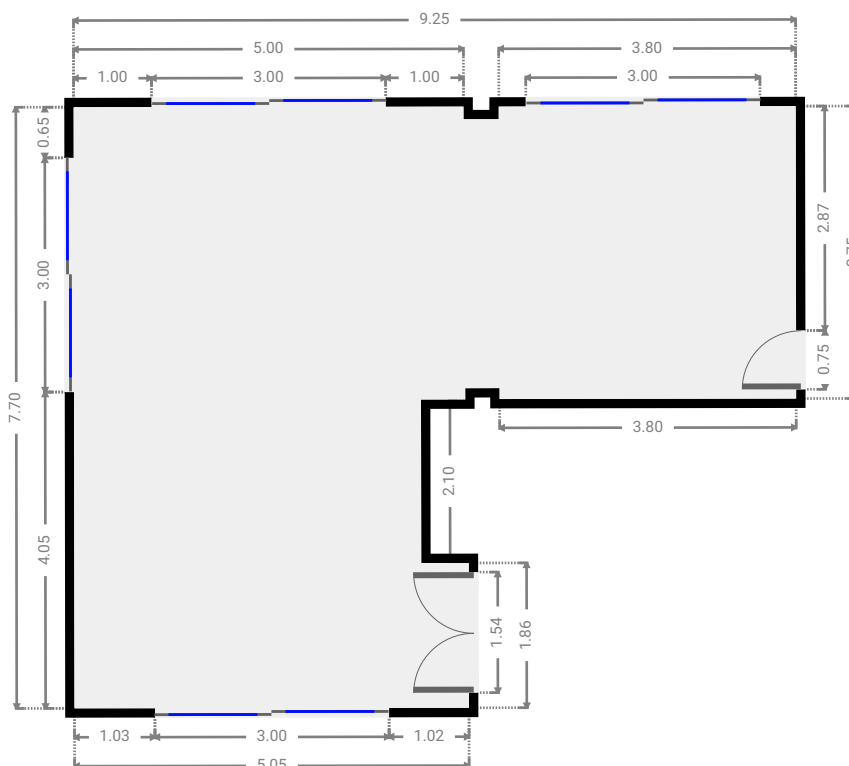
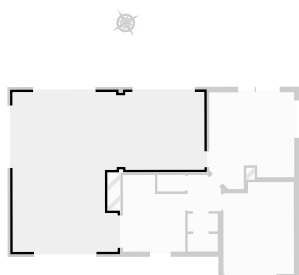

THIS FLOORPLAN IS PROVIDED WITHOUT WARRANTY OF ANY KIND. SENSOPIA DISCLAIMS ANY WARRANTY INCLUDING, WITHOUT LIMITATION, SATISFACTORY QUALITY OR ACCURACY OF DIMENSIONS.

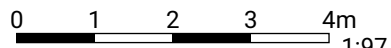

ZILVERBEEKDREEF 19

SURFACE TOTALE : 245.88 m² • SURFACE HABITABLE : 211.09 m² • ÉTAGES : 3 • PIÈCES : 9



▼ Entrée Rez-de-chaussée

LARGEUR : 3.15 m • LONGUEUR : 3.70 m
SURFACE : 10.01 m² • PÉRIMÈTRE : 13.70 m

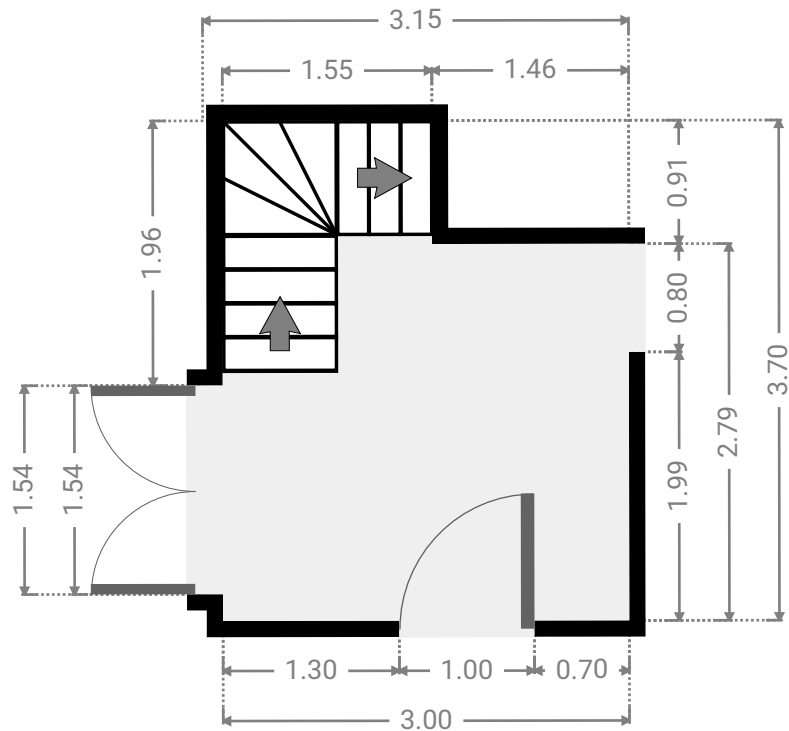
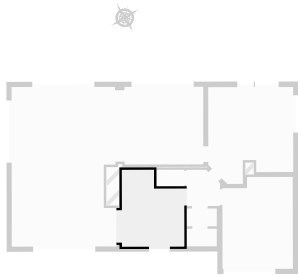

▼ Hall Rez-de-chaussée

LARGEUR : 1.61 m • LONGUEUR : 2.73 m
SURFACE : 4.00 m² • PÉRIMÈTRE : 9.92 m

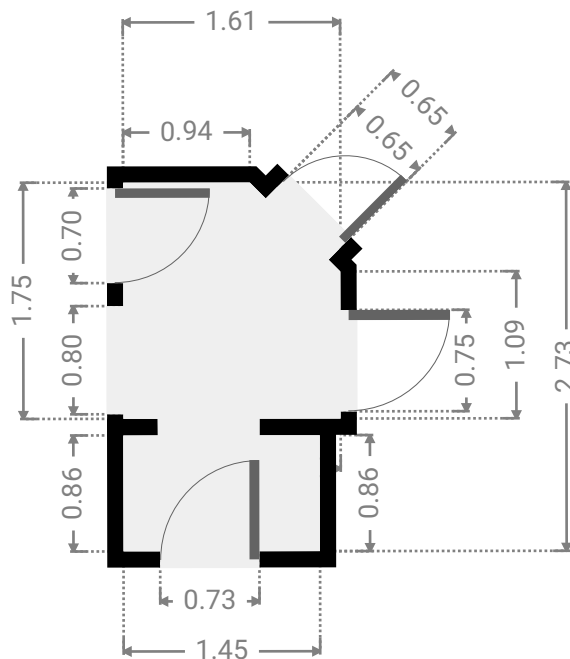
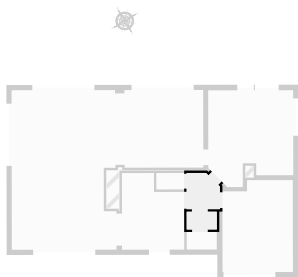

ZILVERBEEKDREEF 19

SURFACE TOTALE : 245.88 m² • SURFACE HABITABLE : 211.09 m² • ÉTAGES : 3 • PIÈCES : 9



▼ W.C.

Rez-de-chaussée

LARGEUR : 1.45 m • LONGUEUR : 0.85 m
SURFACE : 1.23 m² • PÉRIMÈTRE : 4.59 m

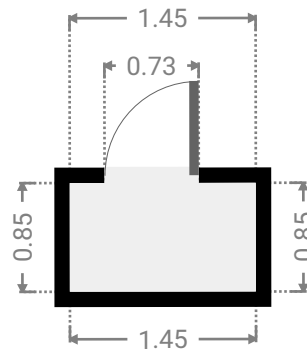
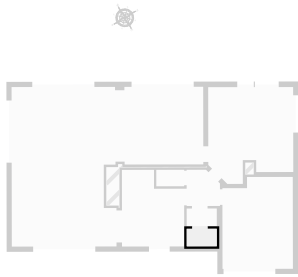

▼ Chambre

Rez-de-chaussée

LARGEUR : 3.40 m • LONGUEUR : 4.44 m
SURFACE : 14.42 m² • PÉRIMÈTRE : 15.66 m

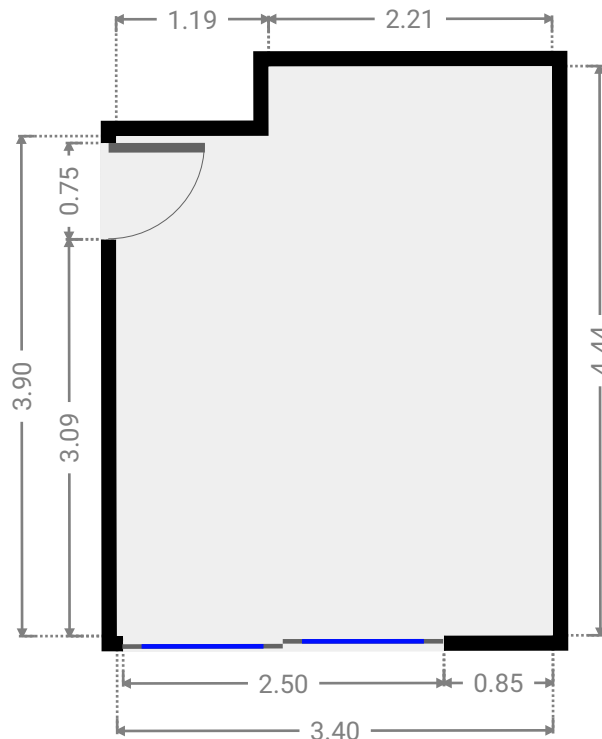
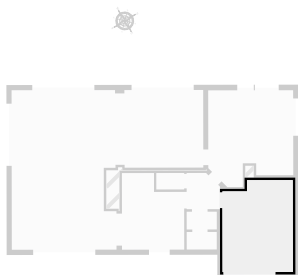

ZILVERBEEKDREEF 19

SURFACE TOTALE : 245.88 m² • SURFACE HABITABLE : 211.09 m² • ÉTAGES : 3 • PIÈCES : 9



▼ Escalier Rez-de-chaussée

LARGEUR : 1.34 m • LONGUEUR : 0.79 m
SURFACE : 1.07 m² • PÉRIMÈTRE : 4.28 m

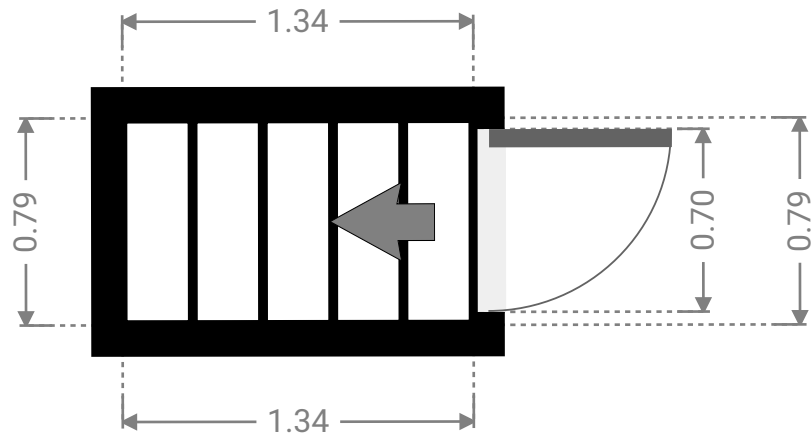
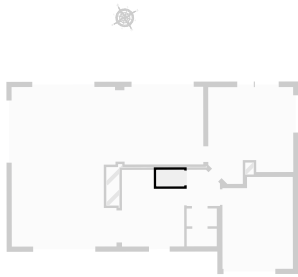

ZILVERBEEKDREEF 19

SURFACE TOTALE : 245.88 m² • SURFACE HABITABLE : 211.09 m² • ÉTAGES : 3 • PIÈCES : 9



▼ 1er étage

SURFACE TOTALE : 84.66 m² • SURFACE HABITABLE : 84.66 m² • PIÈCES : 4

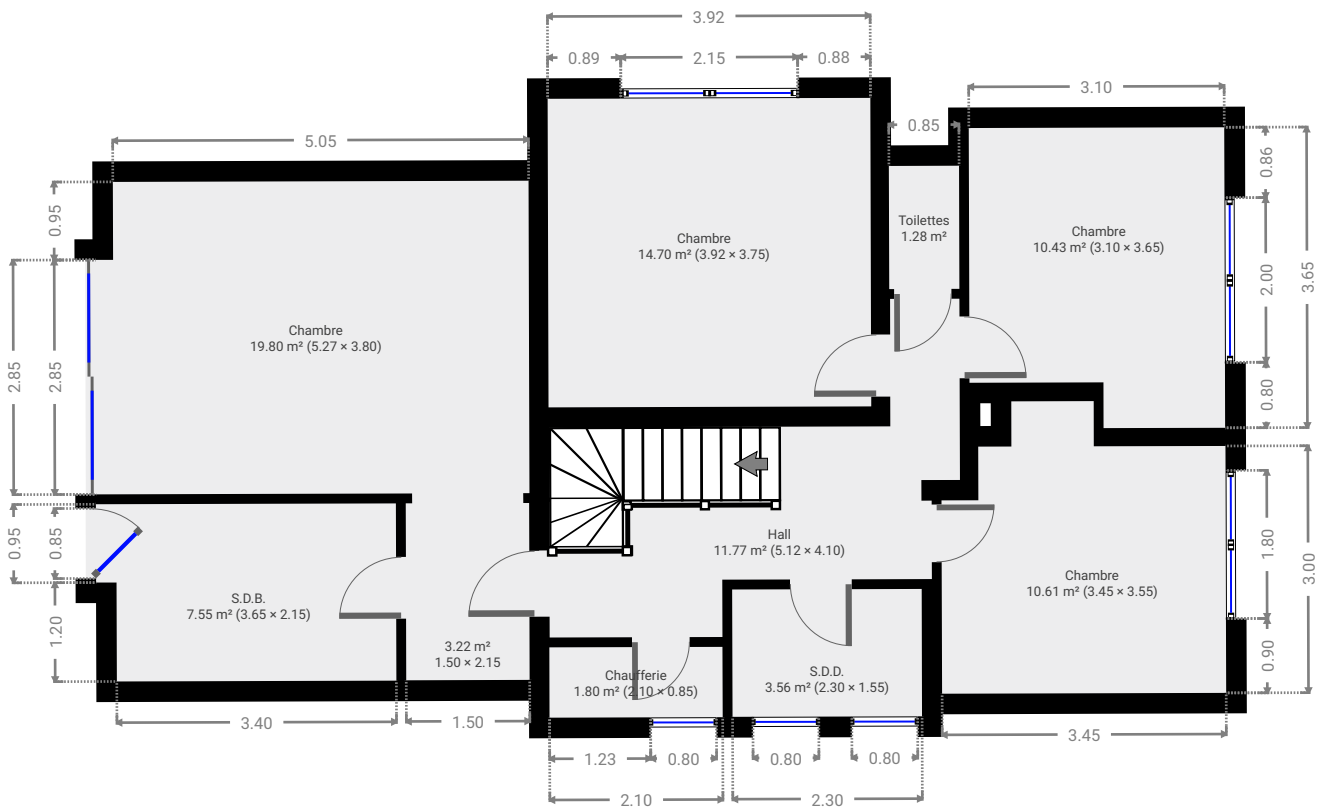

THIS FLOORPLAN IS PROVIDED WITHOUT WARRANTY OF ANY KIND. SENSOPIA DISCLAIMS ANY WARRANTY INCLUDING, WITHOUT LIMITATION, SATISFACTORY QUALITY OR ACCURACY OF DIMENSIONS.

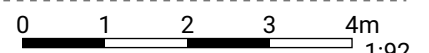

ZILVERBEEKDREEF 19

SURFACE TOTALE : 245.88 m² • SURFACE HABITABLE : 211.09 m² • ÉTAGES : 3 • PIÈCES : 9



▼ Chambre 1er étage

LARGEUR : 3.45 m • LONGUEUR : 3.55 m
SURFACE : 10.61 m² • PÉRIMÈTRE : 14.00 m

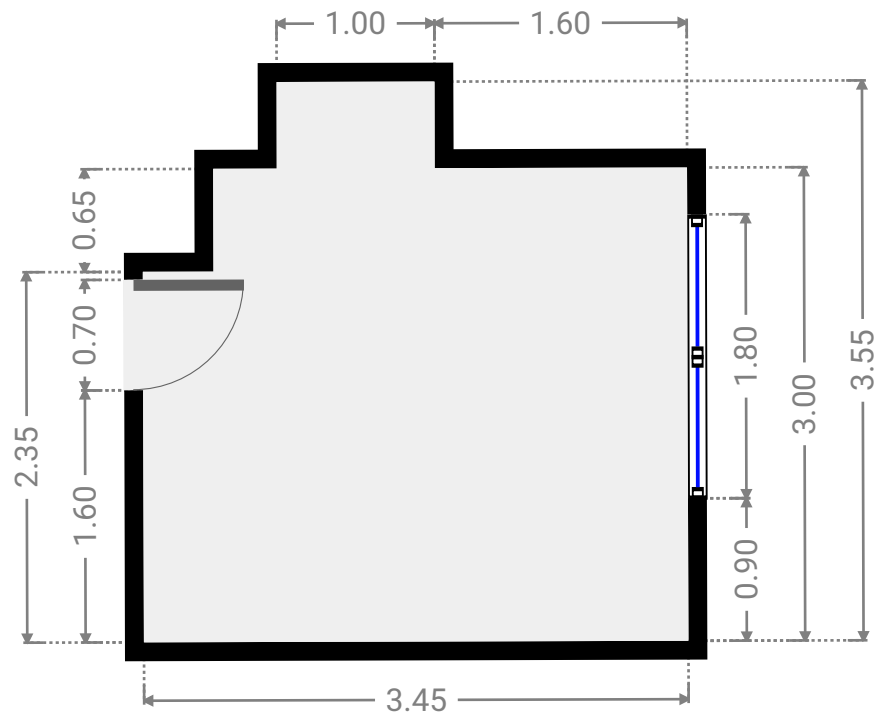
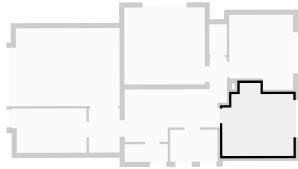

▼ Chambre 1er étage

LARGEUR : 3.10 m • LONGUEUR : 3.65 m
SURFACE : 10.43 m² • PÉRIMÈTRE : 13.51 m

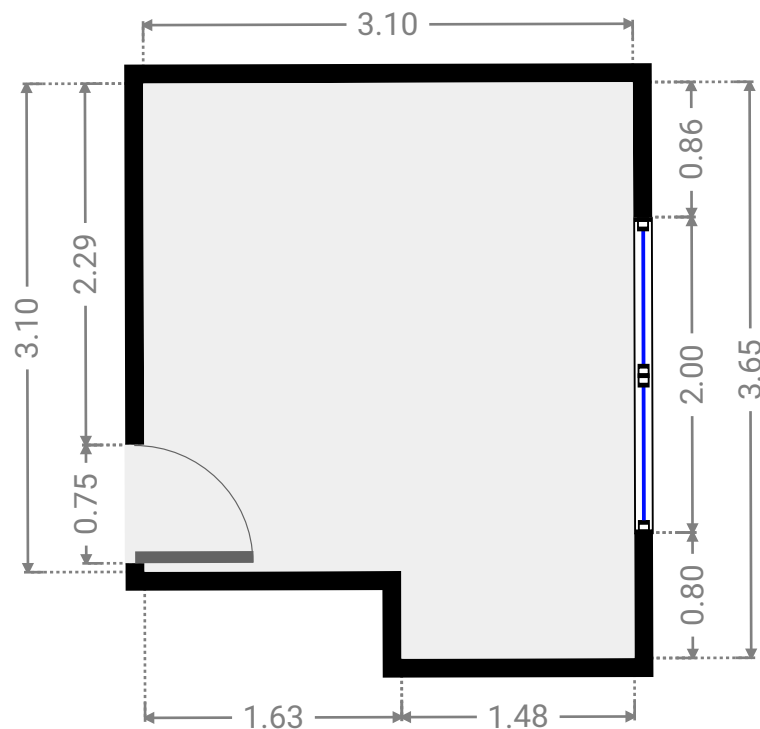
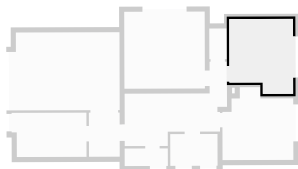

ZILVERBEEKDREEF 19

SURFACE TOTALE : 245.88 m² • SURFACE HABITABLE : 211.09 m² • ÉTAGES : 3 • PIÈCES : 9



▼ Toilettes 1er étage

LARGEUR : 0.85 m • LONGUEUR : 1.50 m
SURFACE : 1.28 m² • PÉRIMÈTRE : 4.70 m

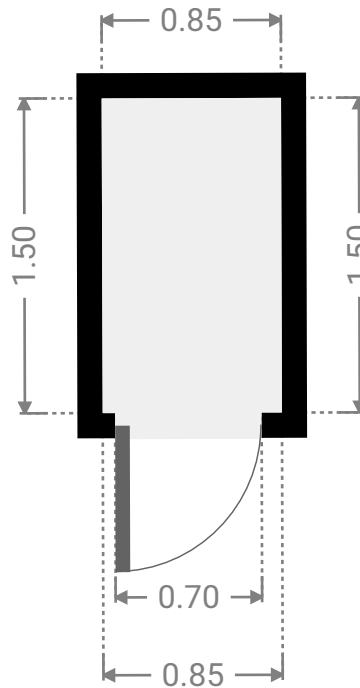
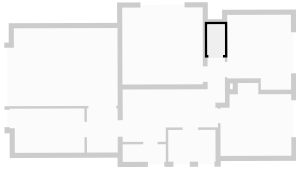

▼ S.D.D. 1er étage

LARGEUR : 2.30 m • LONGUEUR : 1.55 m
SURFACE : 3.56 m² • PÉRIMÈTRE : 7.70 m

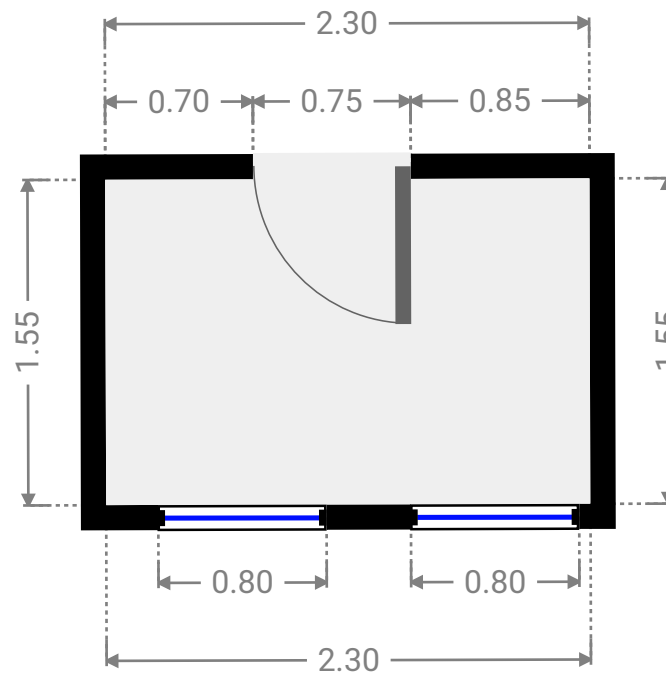
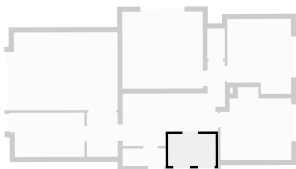

ZILVERBEEKDREEF 19

SURFACE TOTALE : 245.88 m² • SURFACE HABITABLE : 211.09 m² • ÉTAGES : 3 • PIÈCES : 9



▼ Chauffage 1er étage

LARGEUR : 2.10 m • LONGUEUR : 0.85 m
SURFACE : 1.80 m² • PÉRIMÈTRE : 5.91 m

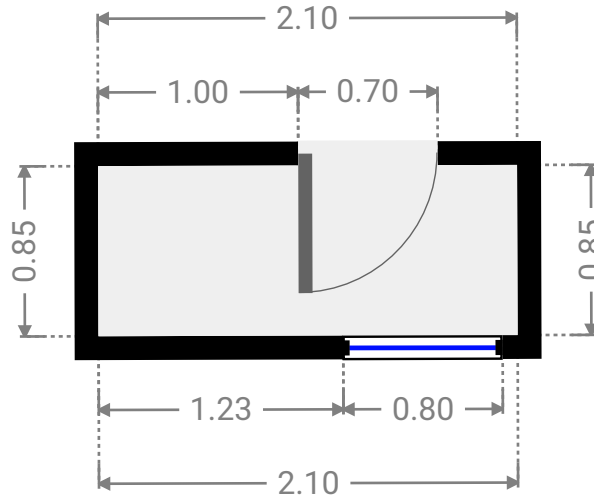
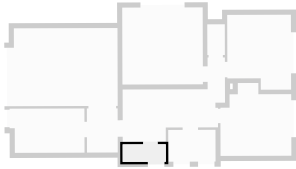

▼ 1er étage

LARGEUR : 1.50 m • LONGUEUR : 2.15 m
SURFACE : 3.22 m² • PÉRIMÈTRE : 7.30 m

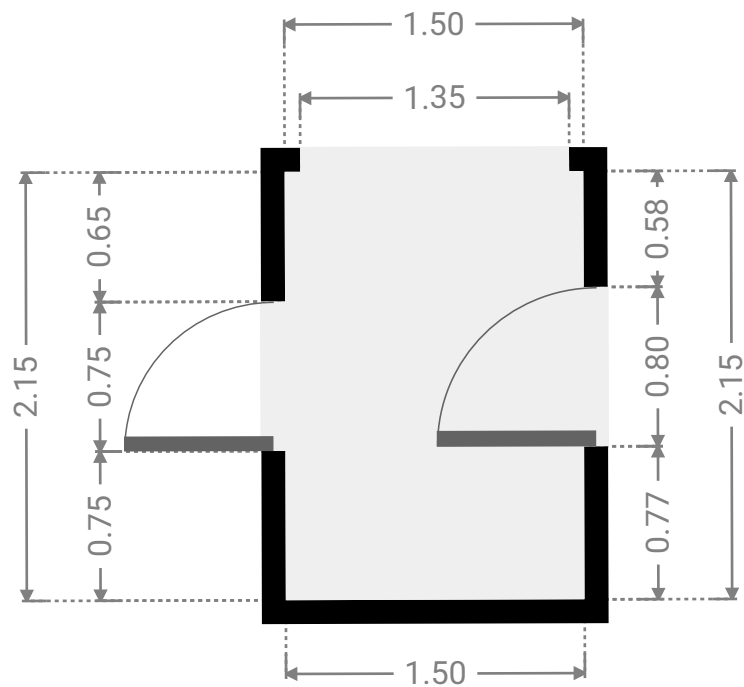
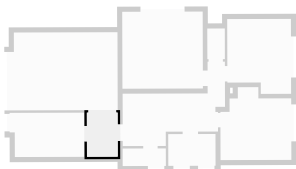

ZILVERBEEKDREEF 19

SURFACE TOTALE : 245.88 m² • SURFACE HABITABLE : 211.09 m² • ÉTAGES : 3 • PIÈCES : 9



▼ S.D.B. 1er étage

LARGEUR : 3.65 m • LONGUEUR : 2.15 m
SURFACE : 7.55 m² • PÉRIMÈTRE : 11.60 m

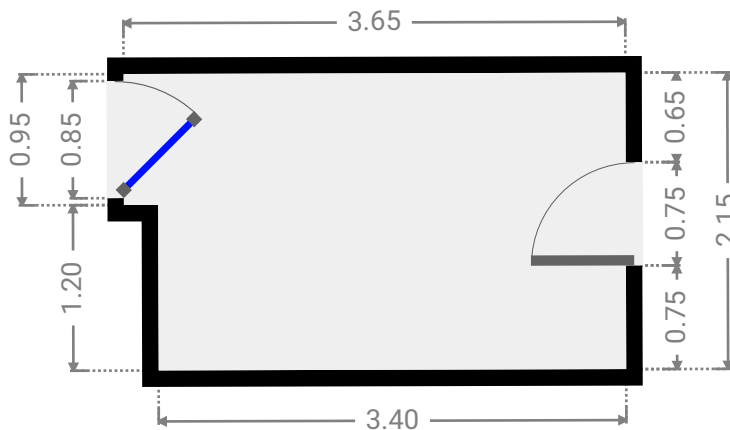
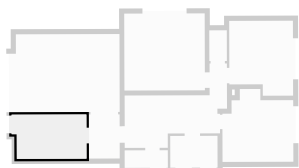

▼ Chambre 1er étage

LARGEUR : 5.27 m • LONGUEUR : 3.80 m
SURFACE : 19.80 m² • PÉRIMÈTRE : 18.13 m

